



Plus-point product diversity

*Installation Manual for Sörensen tail lift:
X1A 500 SL2 and X1A 750 SL2*



Installation Manual

X1 TECHNOLOGY

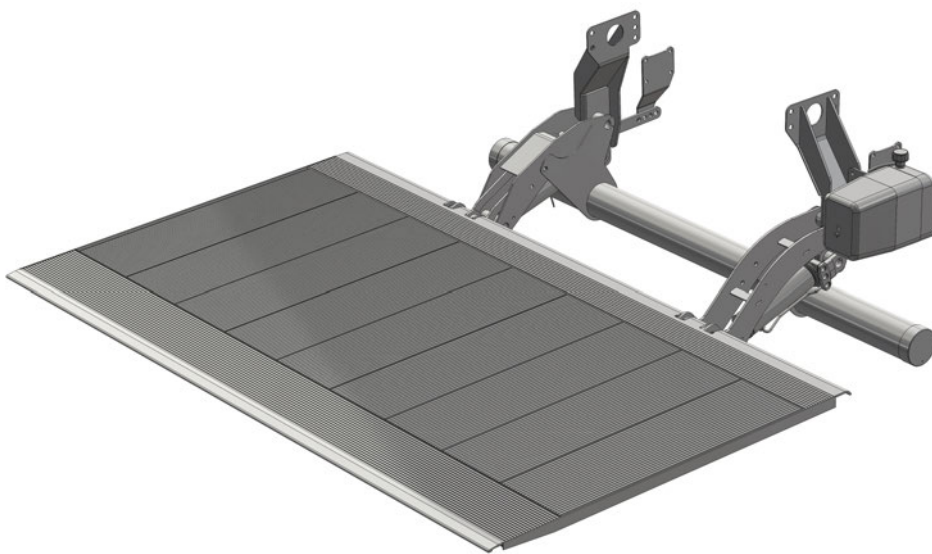

**Installation Manual no.: 20 911 709
for assembly on intermediate frame**





Plus-point product diversity

Installation Manual for Sörensen tail lift:
X1A 500 SL2 and X1A 750 SL2



Sörensen Hydraulik GmbH Osterrade 3 - D-21031 Hamburg

phone: +49 (0) 40 / 739 606 0
fax: +49 (0) 40 / 739 606 66
internet: www.soerensen.de
e-mail: info@soerensen.de



Sales department:

phone: +49 (0) 40 / 739 606 14
fax: +49 (0) 40 / 739 606 69
e-mail: info@soerensen.de



Spare parts:

phone: +49 (0) 40 / 739 606 68
fax: +49 (0) 40 / 739 606 77



...lifts for life

Assembly instructions X1A 500 SL2 / X1A 750 SL2

Introduction

The assembly instructions contain all the necessary information to assemble and adapt the tail-lift on to designated vehicles. If you have any doubt as to whether the tail-lift can be assembled on to a specific vehicle, please call our after-sales department which will provide you with the necessary information.

Modifying the lifting mechanism and the assembly brackets of the X1A 500 SL2 / X1A 750 SL2 is forbidden and would result in the revocation of the operating permit from the authorities and the consequent warranty cancellation.

Deviating from these assembly instructions and/or unauthorized modifications may result in premature failure and operating incidents, as well as putting the operating staff in danger. "Unauthorized modifications" and "deviating from the assembly instructions" will entail the consequent warranty cancellation.

All directives from the vehicle's manufacturer, for the assembly of the tail-lift, need to be complied with, in order to protect the vehicle. Please consult the updated directives for the vehicle you wish to assemble the tail-lift on.



Caution!

The assembly directives of the vehicle's manufacturer must always be complied with

Tail-lift transportation and possible transport damages

The transport company is responsible for all and any damages occurred during transportation. After unloading, the merchandise must be inspected for damages. If damages are detected, they must be written down on the transporter's bill of lading, for eventual claims. The relevant costs can be settled only between Sørensen Hydraulik GmbH, the forwarder or its insurance company.

Precautions during assembly

Please disconnect the battery before assembly. The vehicle must be secure to avoid any unwanted movement on the worksite.

The safety directives of the professional associations must be complied with.

Safety equipment such as goggles, gloves or safety shoes must be provided and used whenever necessary.

The proper functioning of all transport equipment such as forklift trucks, cranes and other lifting devices must be checked before the assembly begins.

During assembly, the vehicle must be protected. We therefore recommend using adequate plastic or adhesive covers.

Ball coupling

If the vehicle is equipped for operating with a trailer, the company responsible for the assembly must guarantee the drawbar clearance and the total vehicle length.

Vehicle preparation

Remove the rear lights and take off the underride bumper if necessary. All assembly measurements can be found on the tail-lift data sheet. All bolts, consoles, brackets or rivets located in the area of the assembly consoles left and right must be removed. If necessary, cut off all hinges or dead bolts from the body.



Caution!

Body seal before tail-lift assembly
See page 20

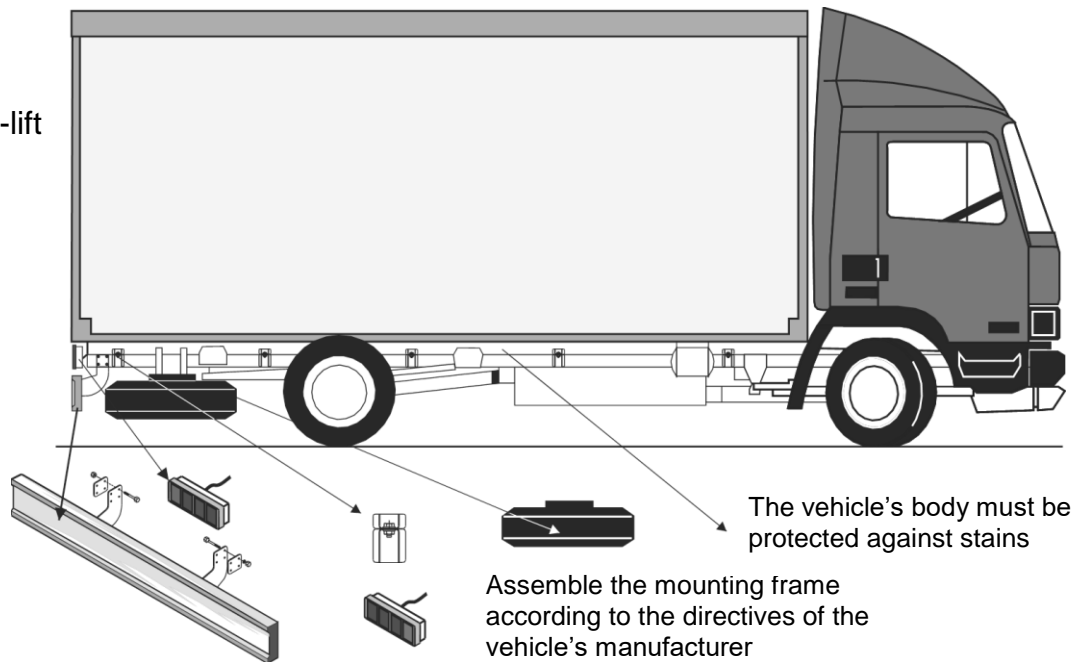
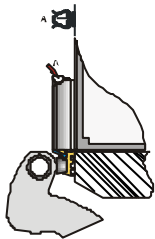

Caution! If the vehicle's chassis needs to be modified, the assembly directives of the vehicle's manufacturer must absolutely be respected. All and any modifications not described in these directives are subjected to written approval.

Cut-outs on the rear vehicle beam

Rear beam cutout measurements

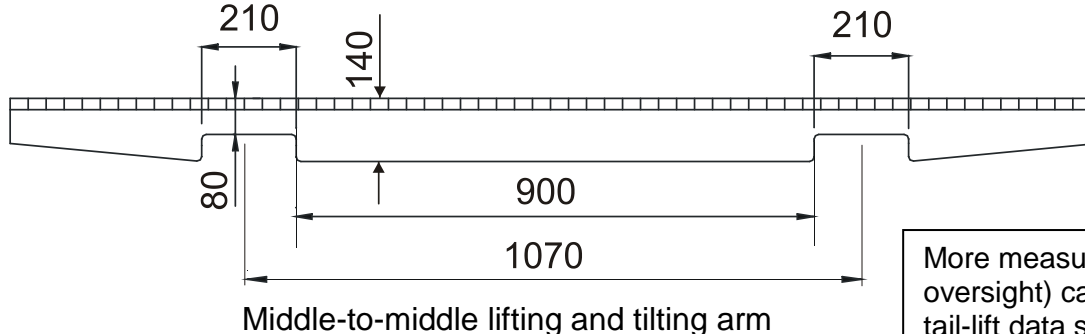

More measurements (side and oversight) can be found on the tail-lift data sheet

Mechanical stands

The assembly directives of the vehicle's manufacturer will state if stands are needed. Please use only those delivered by Sørensen Hydraulik together with the tail-lift.

Assembly preparation



Caution! Before the assembly, it is imperative to check if the vehicle and its technical data is compatible with these assembly instructions. In order to ensure a fast and easy assembly, we offer different lifting arm lengths, consoles and adapters for the different vehicle types.

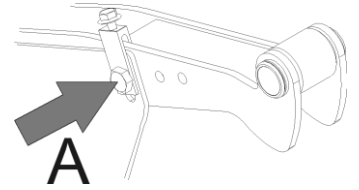

Caution! Before assembly, please make sure that the screw A (link between lifting arm and underide bumper) is loose. It will be tightened only after adjusting the tail-lift (see page 11).

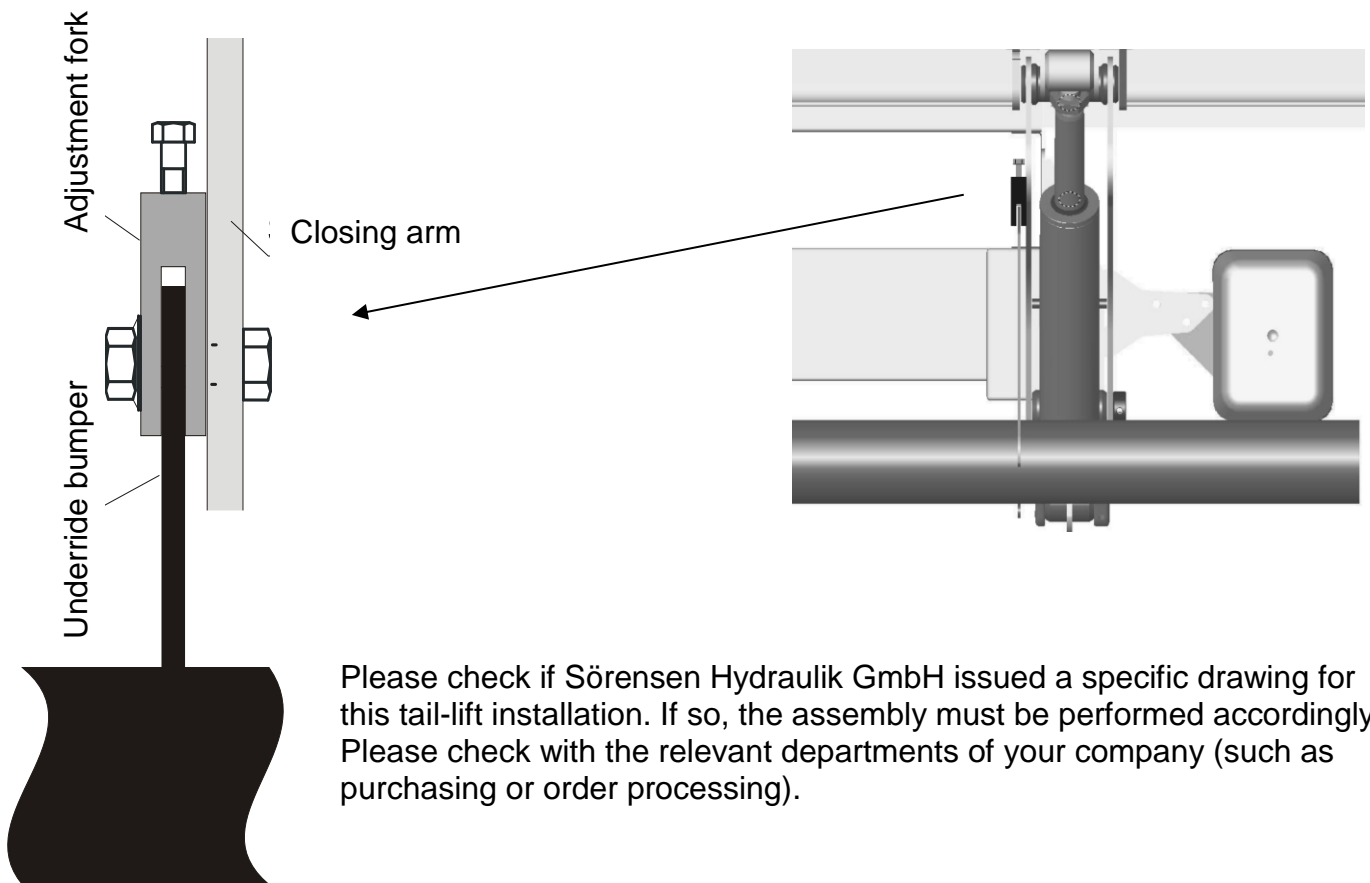

Please check if Sørensen Hydraulik GmbH issued a specific drawing for this tail-lift installation. If so, the assembly must be performed accordingly. Please check with the relevant departments of your company (such as purchasing or order processing).

How to muse the drilling gauges to assemble the lifting mechanism

For the tail-lift assembly, we use drilling gauges (accessory code: 551), which can be delivered with the tail-lift on demand. The gauges feature three components, gauge 1 lies on the vehicle floor, gauge 2 is a replica of the lifting arm and gauge 3 is a replica of the lateral attachment console to be mounted on the vehicle frame.

Different lifting arm lengths and assembly consoles are necessary for the vehicle and frame variations.

variations.

Therefore, there are different versions of gauges 2 and 3, matching the different vehicle and chassis variations.

The gauge is an exact replica of the lifting arms and the assembly console; it is easy to check if the tail-lift parts match the gauge.

The necessary gauges are delivered with the tail-lifts and remain with the customer.

All for the assembly possible min/max measurements can be found on the technical data sheet (assembly data sheet).

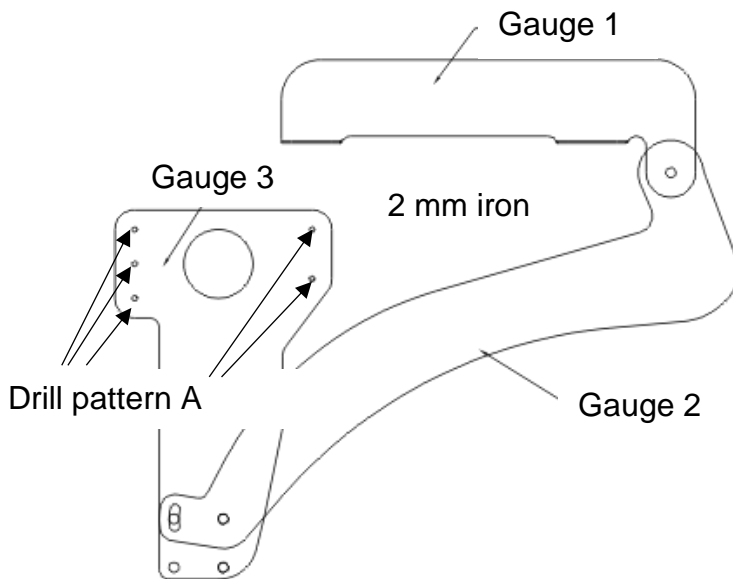

Please proceed as follows:

Place gauge 1 on to the vehicle's floor and secure with a screw clamp.

Hinge gauges 2 and 3, adjust gauge 3 parallel to the vehicle frame and transfer the drill pattern to both sides of the sub frame.

Drill the holes for the tail-lift console.

place parallel, transfer drilling position

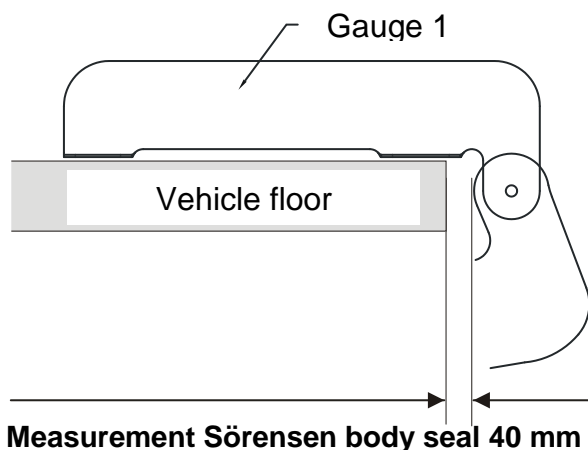
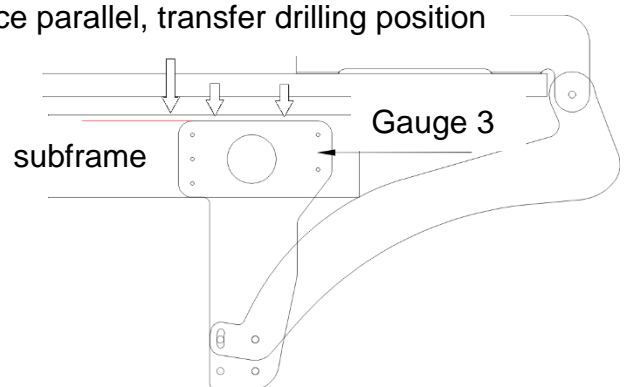

If a body seal is assembled, its thickness needs to be taken into account.

Assembly of the lifting mechanism

The lifting mechanism is delivered on a pallet, already prepared for assembly.

The assembly consoles are assembled on to the sub frame and stabilized on the frame with the supporting rod and the assembly fixture.

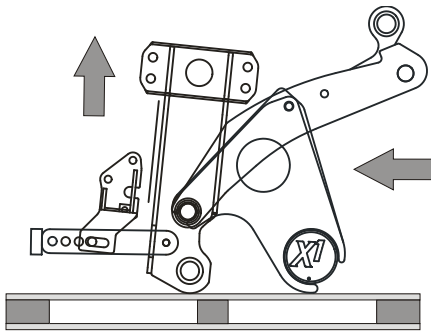

State of delivery (supporting rod and assembly fixture already pre-assembled)

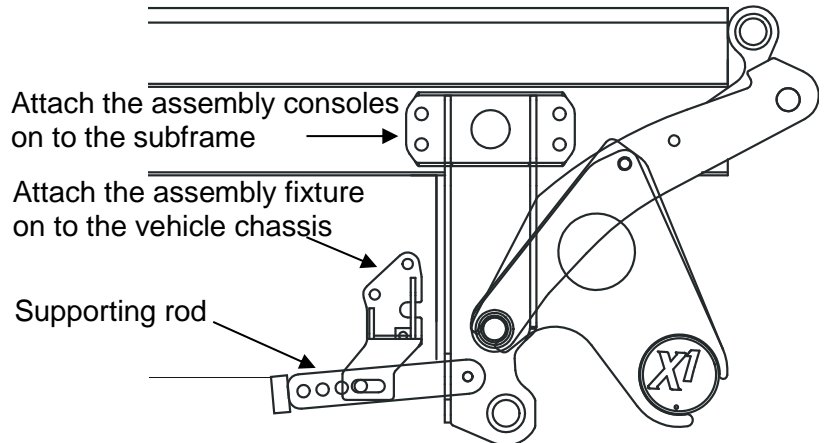

Assembly consoles

Once the holes are drilled into the sub frame, the lifting mechanism is brought under the vehicle on its pallet, aligned with the drilling pattern and firmly bolted onto the sub frame.

On certain types of vehicles, the consoles are mounted on the inside of the sub frame. In this case, the flank of the sub frame must not exceed 60 mm, as this can generate problems with the lifting arm, the hoses and the cables. You will find measurement indications for this (measurement X) on the technical data sheet or on the assembly plan.

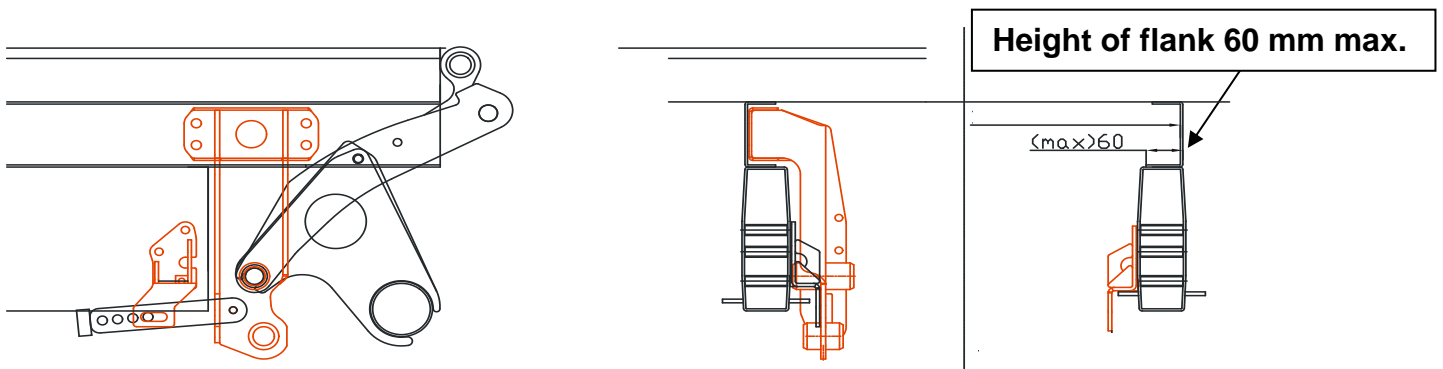

If the space is insufficient, Sørensen Hydraulik GmbH (commercial department) needs to check the assembly situation. If it is determined that the assembly is possible under the stated conditions, we will send you a separate drawing on which that particular assembly is described.

Assembly fixtures

Bolt the assembly fixtures right and left on to the vehicle frame, please use the holes from the original underride bumper. If additional holes should be necessary, make sure to insert spacers into the frame to avoid its collapsing.

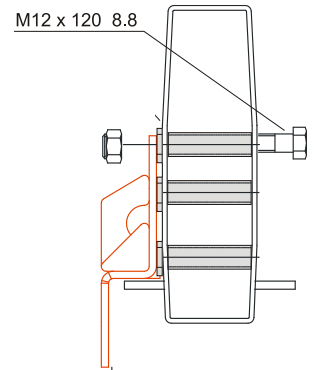

Caution! please respect the assembly directives of the vehicle's manufacturer.

If necessary, fill the space between the assembly fixture and the vehicle frame with washers, so that the supporting rods including the adjustment fork align, meaning that they do not shift laterally when the bolts are tightened.

Installation of the supporting rods and the adjustment forks

When the consoles and the fixtures are firmly bolted onto the frame and the sub frame, the supporting rods and the adjustment forks are installed between the fixtures and the consoles, one set on each side of the vehicle.

The tension of the supporting rod located between the fixture and the console is adjusted with the fork.

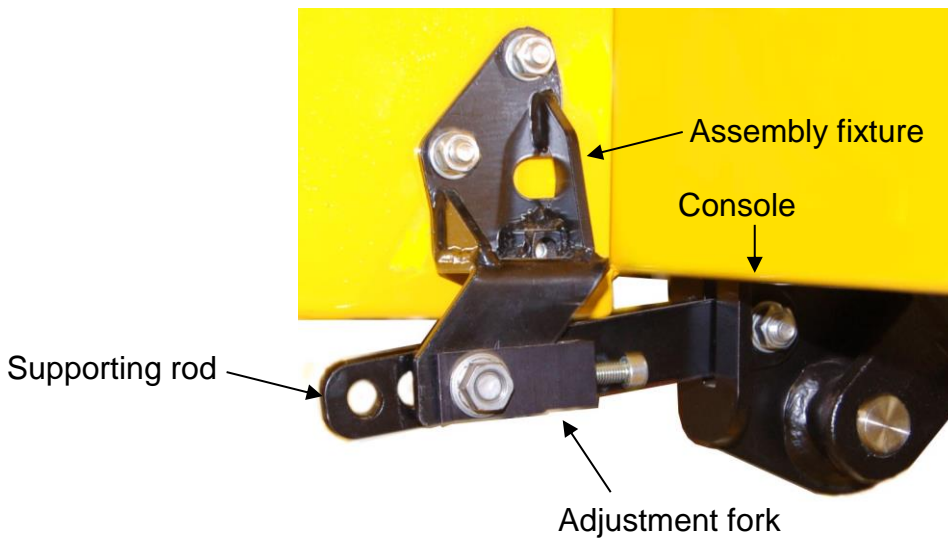
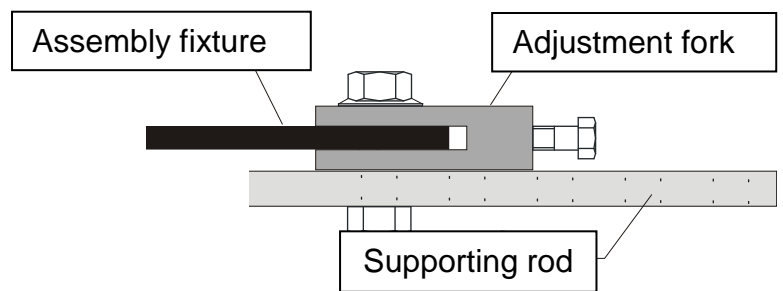

Assembly of the electric system on tail-lifts series 11



Caution!

The tail-lift can only be used if the battery cables are correctly connected and if enough tension is available. Never use a battery charger or a jump starting device, as this will damage the electric motor and the power relay.

Foot control

The foot control is connect to the cable set located inside the platform and has already been factory tested. After assembling the platform, the cable set from the central power unit must be affixed alongside the lifting arm with the delivered cable straps in such a way that no pinching or rubbing is possible

Central power unit

The control unit (main controls, main power unit) containing the service-switch is located inside the power unit and was pre-assembled in our factory. The connections from the power unit's clamping strip (see drawing) to the cabin switch *1, to the control panel *2, to the platform *3, and optional to the cable remote *4, are to be made during assembly. All cables must be affixed on to the device using the delivered cable straps.



Note! No rubbing or pinching of the cables should occur.

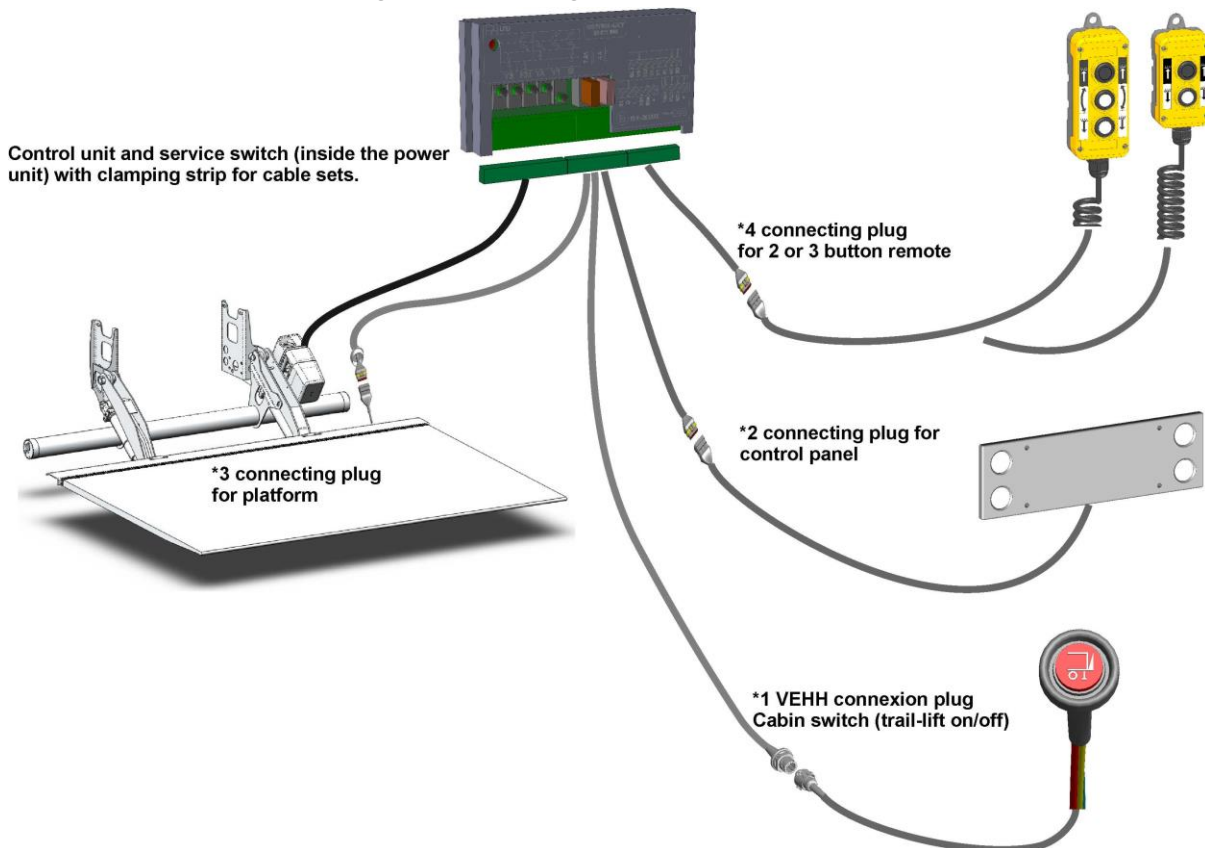

Cabin switch

On vehicles which are not pre-fitted with a VEHH installation, it is necessary to drill a 16 mm hole into the dashboard using, if possible, a free spot. Mount the cabin switch on to the dashboard and connect it according to the delivered connecting plan.

Lead the cabin-switch cable to the tail-lift control unit (main controls, main power unit) and connect it to the round plug of the control-unit. See schematic ***1 cabin switch connexion plug**

Control panel assembly

The control panel is mounted on to the rear right end of the vehicle, so that the operator can see the entire platform at all times.



Note!

The distance must be between 300 mm and 600 mm (European directive EN 1756-1)

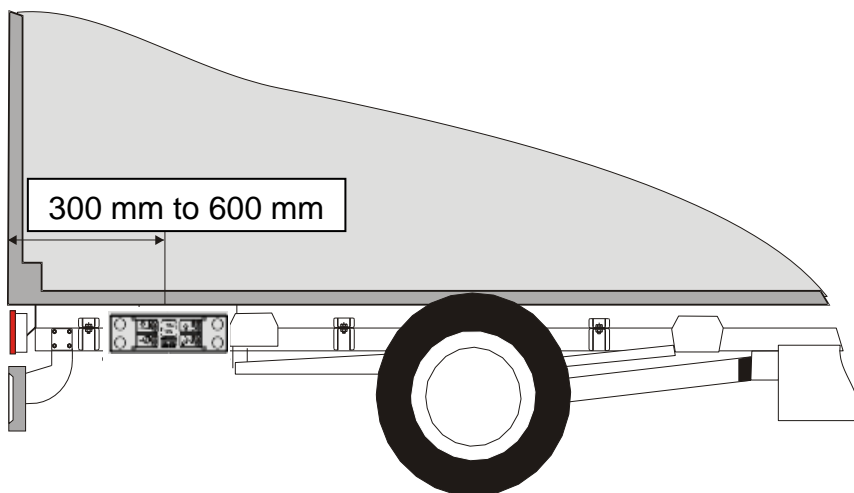
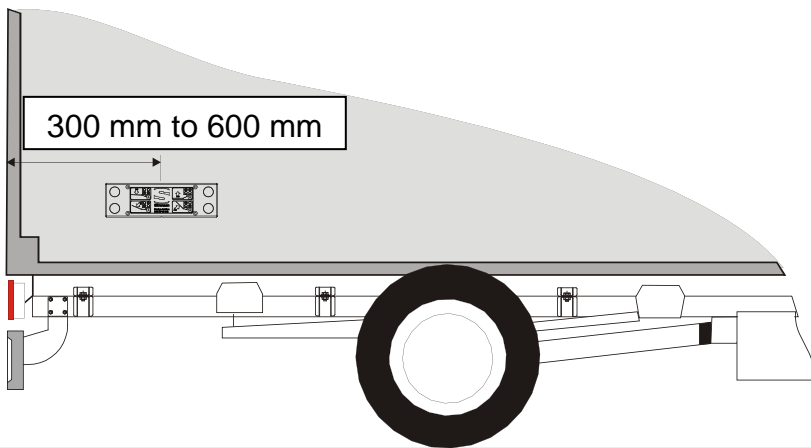

Main fuse

Battery 12 volts	
Battery capacity	1 x 88 Ah
Fuse	150A

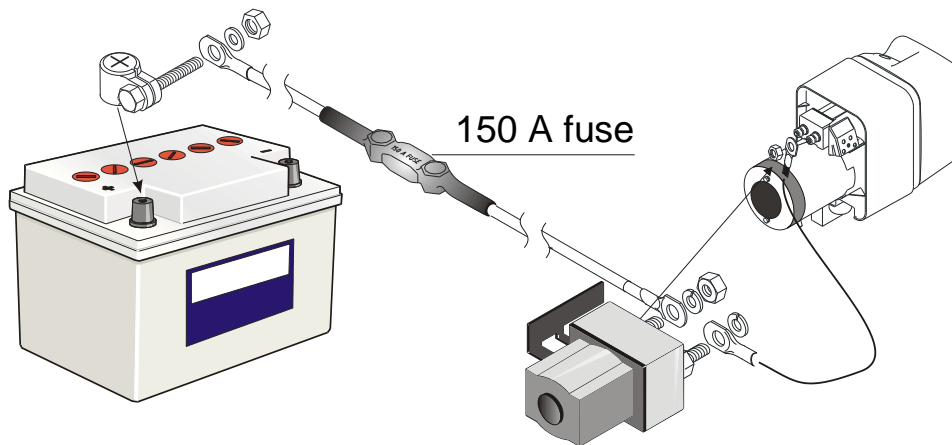

The plus and mass cables are pre-fitted on to the power unit from our factory. Lead both cables to the designated location of the vehicle. The mass cable is blue, the plus cable is red. Please ensure that there is no rubbing or pinching and that the cables do not come close to heat sources.

! Caution! The directives of the vehicle manufacturers must be complied with.

! Caution! The maximum load of 500 kg or 750kg must not be exceeded in order to avoid serious damage to the vehicle.

Maximum load must be positioned in the centre of the platform and loading distance of 600 mm must not be exceeded.

Also see type label on the lifting arm and inside the power unit cover.

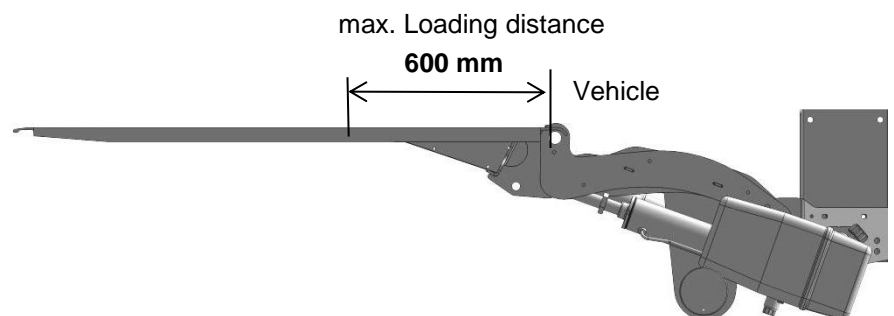

Safety sticker “Safe operation of the tail-lift“

This sticker is delivered with any new tail-lift. The company performing the assembly must place it at the rear end and inside the vehicle’s body, visible for all to see. This sticker describes with pictograms eventual misuse and the correct operation of the tail-lift.

We would like to thank the assembly companies for their support in achieving the goal to advise the operators clearly and precisely regarding the correct use of the Sørensen tail-lifts.

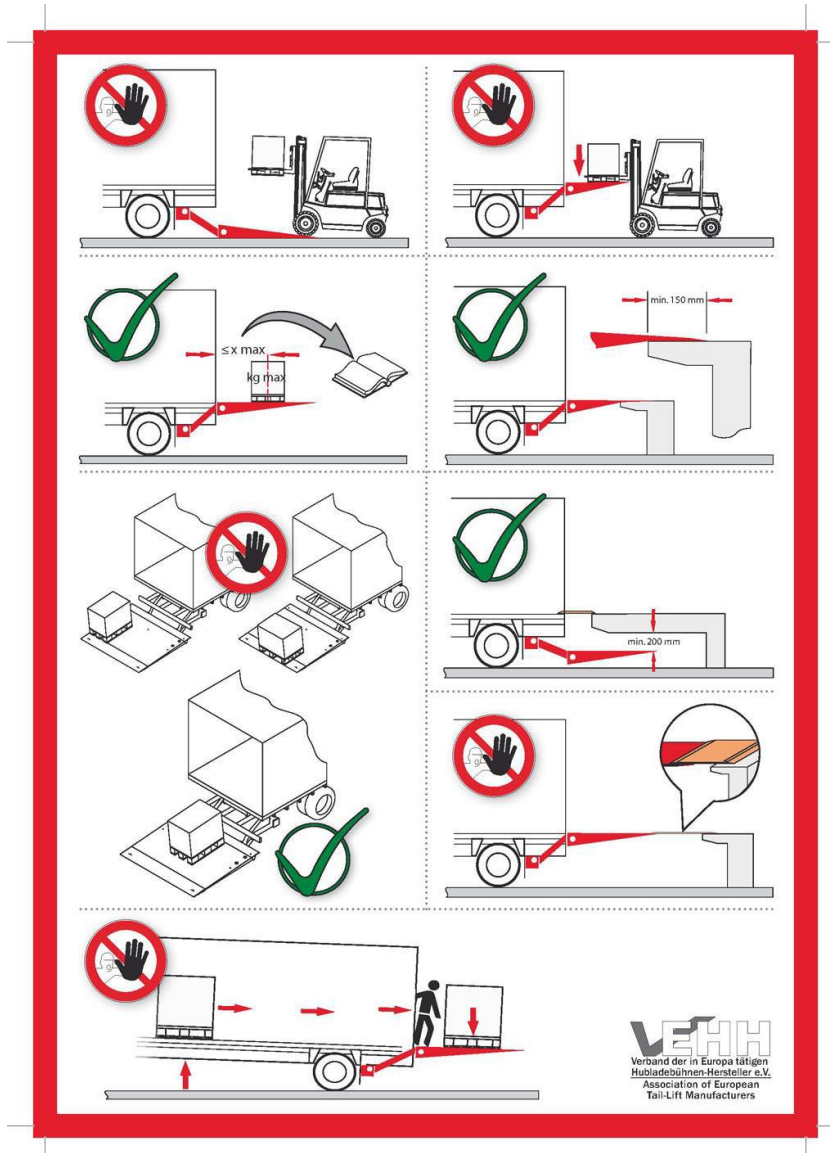

This sticker can also be ordered separately under number 20 909 238

Platform assembly and adjustment

Type	A	B
X1A 500 SL2 X1A 750 SL2	180	58

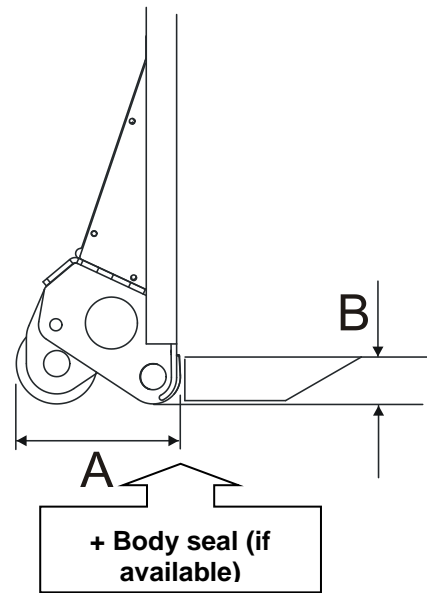

Platform assembly

Lower the lifting mechanism to facilitate the platform assembly. Grease the mountings of the lifting swing and of the tilting arm with our special grease, place the O rings, hinge the lifting arms and the tilting cylinder, place and secure the bolts.

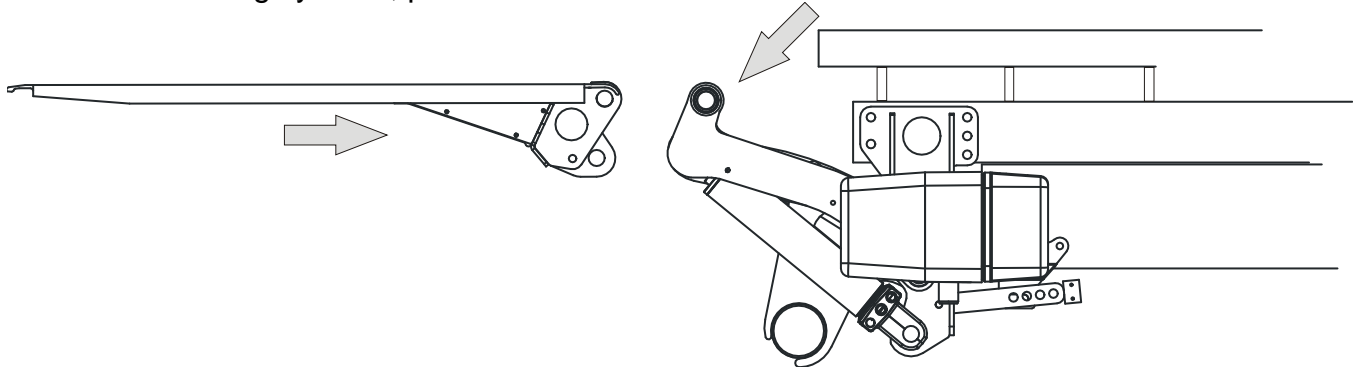

Adjusting the platform to the vehicle's floor

With the platform open and using the power unit, lead the lifting arms towards the rear beam of the vehicle. To perform the adjustment, the lifting arms must not touch the beam. Please leave a distance of about 10 mm between the lifting arms and the beam. With the adjustment screw, position the platform parallel to the beam. After the adjustment, tighten both screws (A) of the underside bumper attachment.

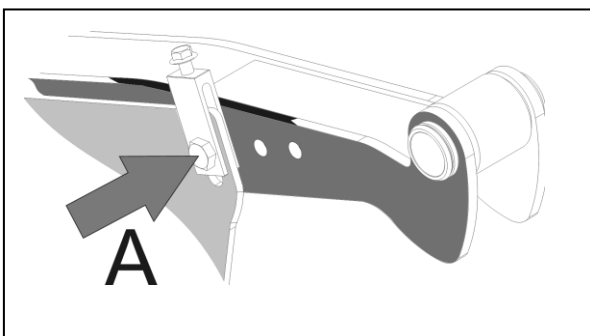
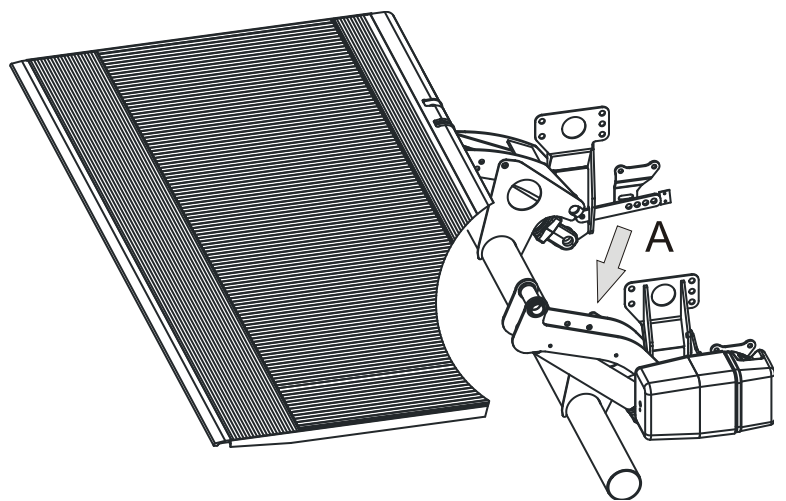

Functioning of the adjustment fork

After the assembly, both lifting arms must touch the rear beam at the same time and must not give way when loading the platform. If necessary, this adjustment is made with the adjustment fork located on the right lifting arm. If the screw is turned to the right, the lifting arms run tighter against the beam.

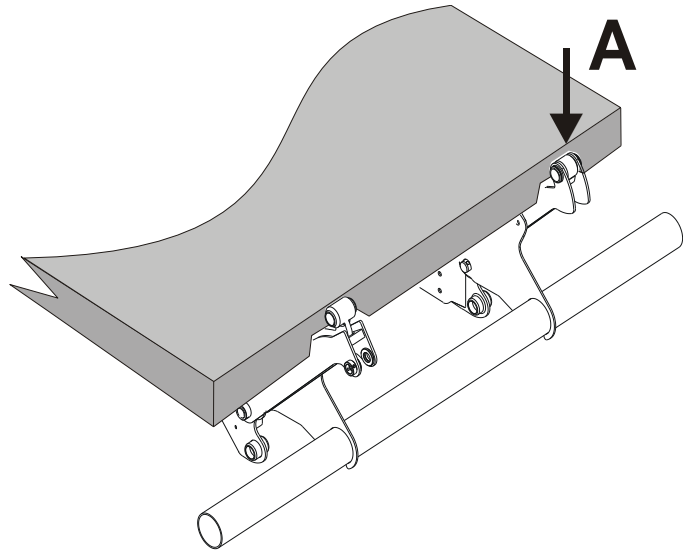

If the screw is turned right, the lifting arms run tighter against the rear beam

If the screw is turned to the left, the lifting arms will run looser against the rear beam.

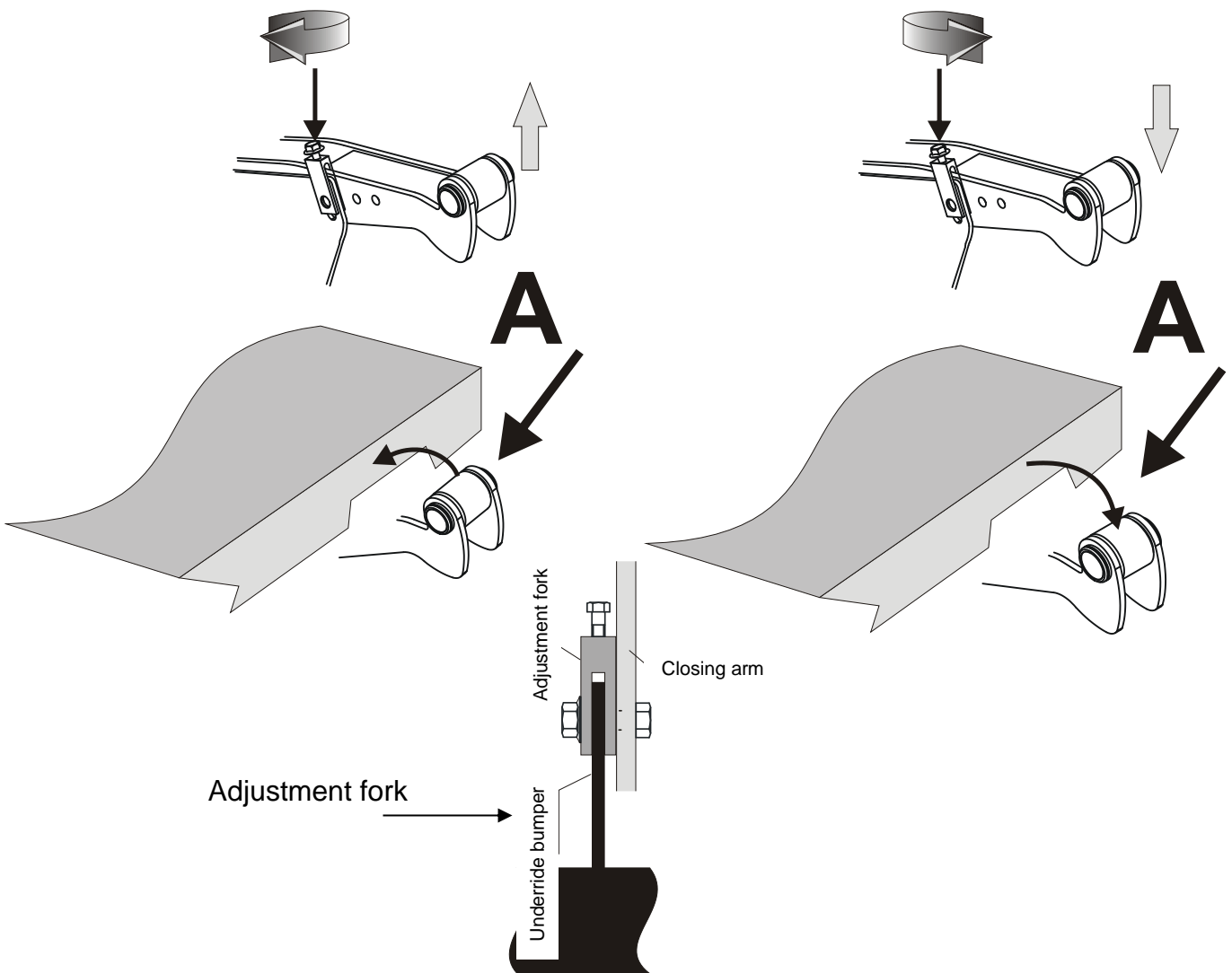

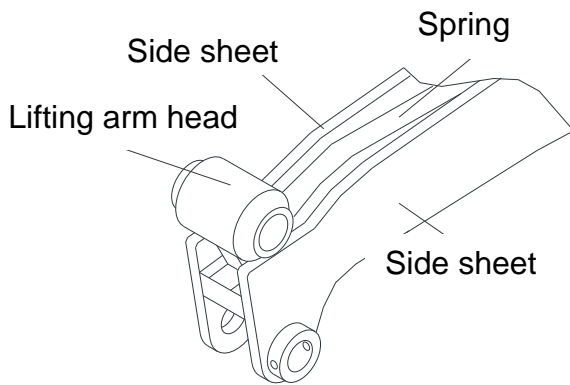

Lifting arm pressing against the vehicle's body

If the assembly was performed correctly, both lifting arms will press against the rear beam at the same time.

If the shape of the rear beam does not allow that, it is essential that the lifting arm presses only with the spring head against the beam and that the side sheets can press freely onto the lifting arm's head.

Eventually, the pressing area must be reinforced to prevent deformation when operating the tail-lift.

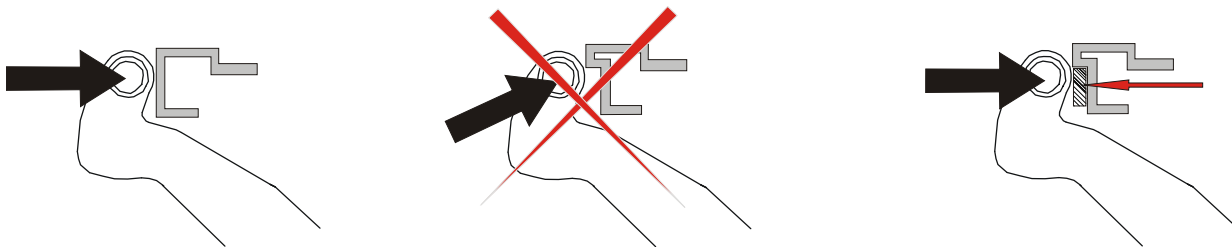

The lifting arm head must always press against an even surface. If the rear beam is not evenly shaped, please fill it up to create an even surface. Otherwise, the body could be lifted and the spring part of the lifting arm would no work correctly.

Adjusting the closed platform

Close the platform completely with the power pack. The cylinder must be completely deployed (mechanical stop inside the cylinder) when the platform presses lightly against the body or when it is in a 90° position of the vehicle floor. If the platform presses too hard against the body with the cylinder not fully deployed, the cylinder's rod length must be adjusted.

Open the platform 10° to 15° in order to slacken the cylinder. Open the counter nut on the piston head and screw or unscrew the cylinder's head. Test to ensure that there is a light pressure and tighten the counter nut.

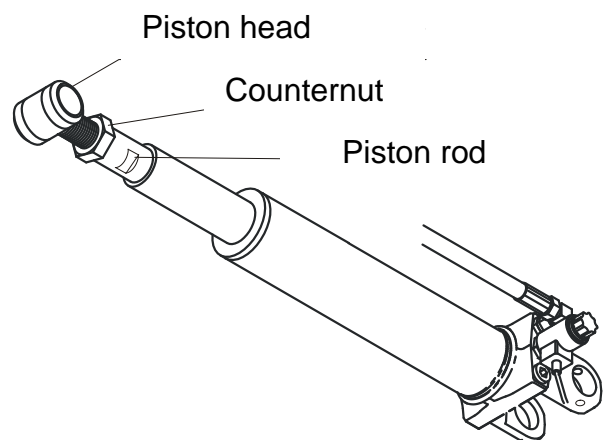

Platform tilting adjustment on series 11 (Tilting sensor programming)



Caution! This version is not compatible with the previous cable sets.
The adjustment is performed with a button sequence on the control panel.

After assembly or repairs

On the control panel

Put the platform in horizontal position

Press the button 1 (top left) three times, then

Press the button 2 (top right) three times

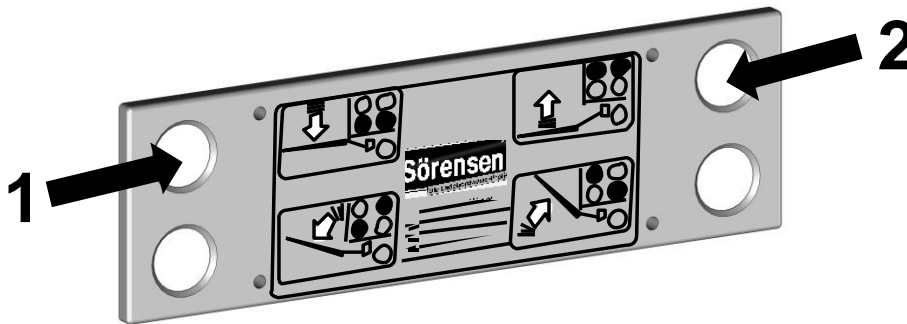

This position will remain active until the next programming.

Tail-lift's first operation

Check if the tail-lift is operational. Check if all movable parts can move freely (no rubbing of hoses or cables etc). Check the hydraulic system for leaks.

Proposals for the hydraulic oil.

HLPD 22 (ISO-VG 22) "detergent" to emulsify the exceeding water, (amongst other things because of ice forming in winter) and for better adherence of the oil film.

Sörensen hydraulic oil HLPD 22 product code 60 700 283

Sörensen hydraulic oil HLPD 10 product code 20 841 181

Sörensen biological oil product code 20 858 811

Painting the lifting mechanism

The lifting mechanism is delivered painted KTL black or epoxy coated. If a different colour is desired, it must be requested by the company performing the assembly. (Please note that the epoxy must be roughened before painting). Also note that the black piston rods must be protected with adhesive, and cleaned thoroughly for paint and adhesive remains, to avoid damaging the seals, which would void the warranty.

Operating instructions

The label containing the operating instructions was glued on to the control box in our factory

Type label

The type label containing the loading diagram was glued on to the lifting arm (in driving direction on the right) a second type label was glued inside the power pack cover in our factory.

Test book entry

After assembly, the test book part "test before first operation" must be filled in and signed by a qualified person.

Testing operation speeds

Vertical speed

The vertical speed (lifting and lowering) must not exceed 15cm/sec. If this speed is too high, compare the vehicle's and the power pack's electrical tensions, which must be identical. If the opening and lowering speeds are too high, please check the function and the cleanliness of the hydraulic throttles.



Caution! In both cases please call the after-sales department of Sörensen Hydraulik GmbH!

Opening and closing speeds

If the platform is not opened and/or closed manually, the angular speed must not exceed 10° per second.

Tilting speed

The angular speed must not exceed 4° per second. The tilting of the platform must be limited to a maximum of 10°

Load test

Static test

Place the platform in a horizontal position, half way between the road and the vehicle floor. Place a testing load up to 125% of the tail lift's nominal capacity at the authorized loading distance onto the platform. The lift's nominal capacity and the authorized loading distance are engraved on the type label of the device. The loading diagram states the possible loads when modifying the loading distances. In a test time of 15 minutes, the platform must not lower more than 15mm nor tilt down more than 2°



Caution! It is mandatory for the company performing the assembly to check if there are any deformations on the tail-lift after the static test.

Dynamic test

Lifting, lowering and tilting functions are to be verified with the authorized loads stated on the loading diagram. If necessary, adjust the overload valve so that the stated load can be lifted securely.



Caution! The overload valve is adjusted in the factory, a correction is usually necessary. Nevertheless, if it should be the case, please note following points: Adjust the overload valve only if the pressure can be read through a manometer. The authorized maximum pressure is engraved in bar on the tail-lift's type label. After performing the static and dynamic tests, the hydraulic system must be visually verified for leaks.

Overload test

A test must ensure that a load greater than 125% of the nominal capacity can not be lifted.

Safety equipment test

Use all the tail-lift's functions until the safety equipments are triggered.

Warning flags

Mount the delivered warning flags according to delivered instructions



Distance **A** – 20 mm clearance between the open platform and the road

Distance **B** – place the left and right flags as close as possible to the outside platform edges

Valid torque chart for all delivered and assembled screws on Sörensen tail lifts.

Screw dimensions 8.8	Torque in Nm	Bolts DIN 3852	Torque in Nm
M4	2.7	G1/4"	40
M6	9.5	G3/8"	95
M8	23	G1/2"	130
M10	46		
M12	80	12L	
M14	130	16L	60
M16	195	18L	60
M20	385	Plug	
		G1/8"	15
10.9		G1/4"	33
M10	70	G3/8"	70
M12	115		
M14	180		
M16	275		
M20	542		

LED diagnostics

Explanations for LED diagnostics of the control unit with service switch on series 11
 (Main electrical system, main control unit with service-switch)

Series 11 control-unit

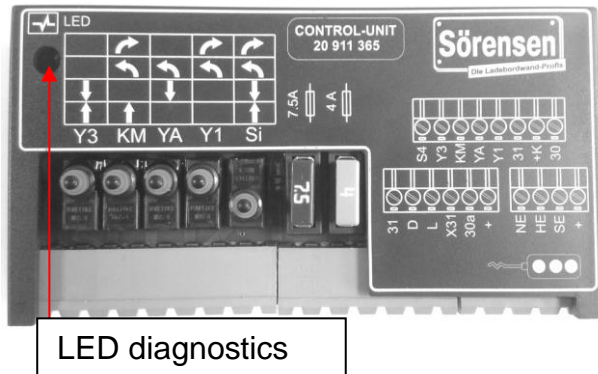

LED stays on when:

Cabin switch is on or
 Platform position 60° to 90°
 Platform position 0° to -10°
 Explanation: Platform CLOSED (vertical) 90°
 Platform OPEN (horizontal) 0°
 Platform tilted down -10°

LED tilting when:

Hand buttons are triggered
 or
 Foot control is used
 or
 Remote is used

LED off when:

Cabin or key switch is off
 or
 Platform position 0° to 60°

Checking the inclination sensor inside the platform

Platform closed and tail-lift switched on:

LED on
 Electrical supply OK

Platform position 0° to about 60°
 LED off
 Inclination sensor S1 triggered and OK
 Corner lights are activated

Platform position 0° to -10° (platform tilted down)
 LED on
 Inclination sensor S2 activated and OK
 The switch occurs in horizontal position. This allows adjusting the automatic lifting inclination

Checking the pressure switch S4:

Start lowering with both foot control buttons.
 LED blinks

As soon as the platform reaches the ground, and the pressure switch is triggered, the blinking stops and the LED stays on. LED is on and the platform tilts down.

This shows that the pressure switch was triggered. If not, the pressure switch is defective.

Service Switch

Authorized personel can use and test all tail-lift functions directly with the service switch located in the power unit.

In case of failure of the hand or foot controls, the tail-lift can be driven into any position by authorized personel (emergency function)



Option body lighting

The clamping strip located on the service switch can be used to connect the body lighting. To connect the body lighting, connect the lightningcable on the clamp “K+” and the clamp “31” on the clamping strip or on chassis instead clamp “31”. It is turned on and off with the cabin switch together with the tail-lift and is protected by a 4 Ampere fuse.

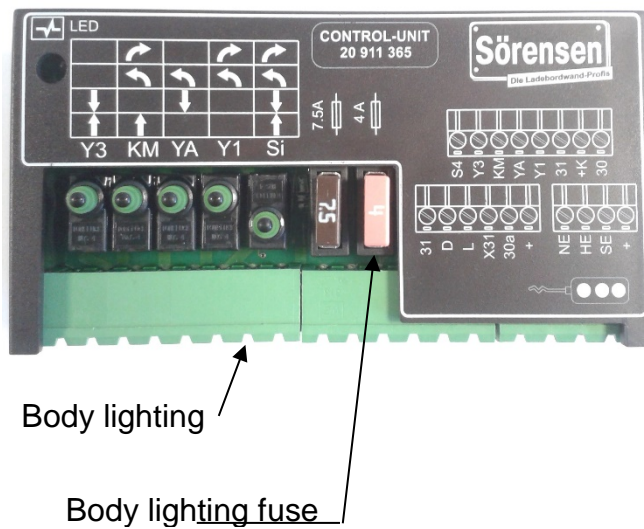

Fonction	Y3	KM	YA	Y1	Si
Lifting	•	•			•
Lowering	•		•		•
Open / tilting down		•	•	•	•
Closing / tilting up		•		•	•

Please respect the sequence, KM always last

Body seal assembly

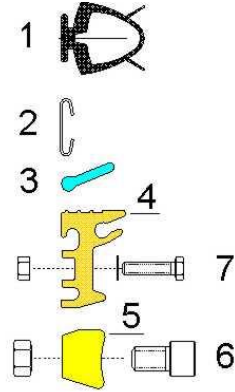
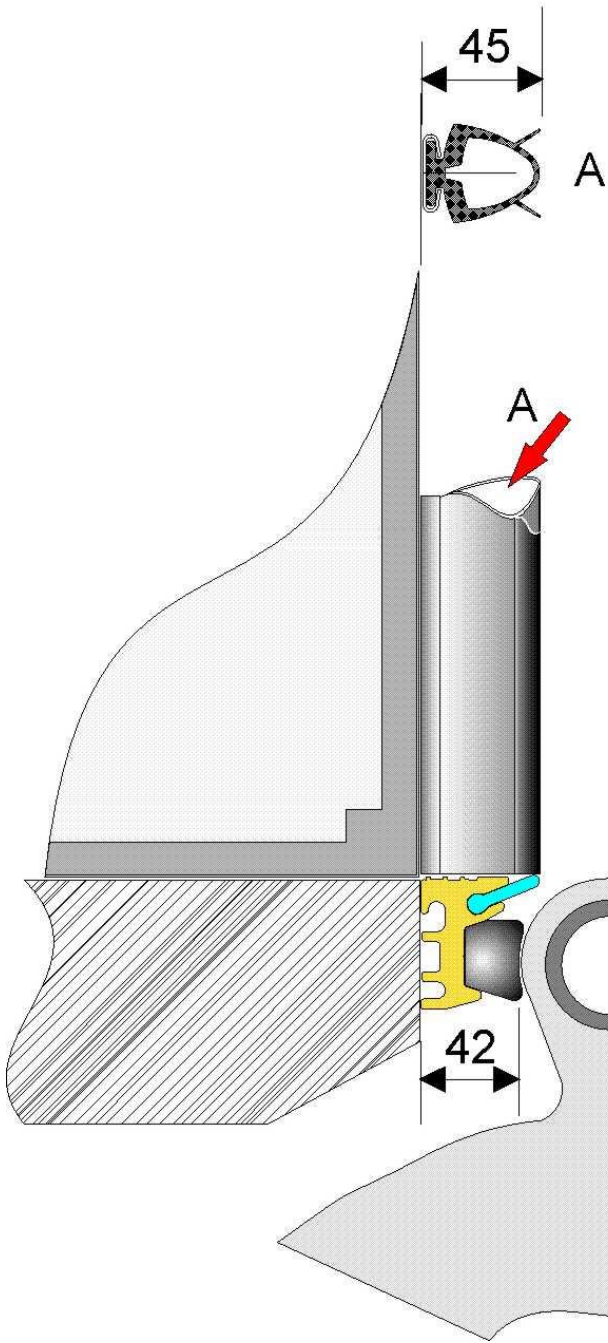

1 Rubber profile	20 840 321	3,0 m
2 Aluminium rail	20 840 542	2,6 m
3 Rubber profile	20 904 899	2,5 m
4 Aluminium profile	20 905 044	2,5 m
5 Stop 150 mm wide	20 908 416	2 units
6 Allen screw	20 905 217	4 units
7 Hex screw	20 905 218	6 units

Nuts are not part of the delivery

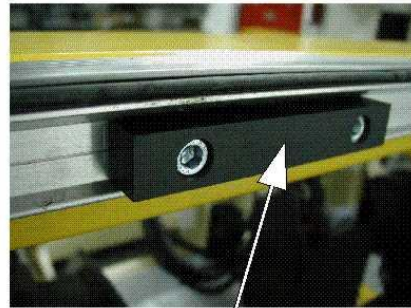

Stop spacing:
Middle to middle lifting arms.